

## Technical parameters

Power supply voltage (V)	9 – 36
Max load current of outputs (mA)	1
Max current consumption (mA)	100
Working temperature range ( )	- 40 -- + 80
Interface : digital EIA 485 (2 pcs.) (halfduplex)	Analog 0.3-9.6V, frequency 500-1500Hz
Max Fuel Level (M)	1
Degree of protection	IP66

## Description

J10ULM Ultrasonic fuel-level meter is used for fuel level measurement in vehicle fuel tanks in order to control fuel consumption. The measurements are realized by the ultrasonic radiator installed directly on the external bottom part of the fuel tank and data processing box. The ultrasonic fuel-level meter can measure levels of diesel and petrol or other liquid materials depending on software settings. contactless ultrasonic liquid-level meter for the tanks up to 1 meter height. Measurement of the fuel and oil level in vehicle tankers, railway tankers, fuel tanks of motor ships and diesel locomotive etc. J25ULM modification additionally measures density of the liquid.

## Application:

Contactless ultrasonic fuel-level meters are designed for measuring liquid level without putting it in a liquid. They could be used as being connected to a GPS/ GPRS tracker so as an autonomic device.

The contactless ultrasonic fuel-level meters conform to the most strict fire and explosion safety requirements.

The ultrasonic fuel-level meters could measure level of the following liquids:

Gasoline, Diesel, Liquefied gas, Liquefied CO<sub>2</sub>, Alcohol, Milk, Acid, Kerosene, Paint, Solvent ..... and so on liquid.

Default setting of the measuring liquid is diesel. For the other liquids corresponding settings should be made.

Specific features of the ultrasonic fuel-level meters:

1. Superimposed method of the installation without tank drilling
2. No contact with the fuel
3. High fire and explosion safety
4. High measurement accuracy
5. Thermo compensation
6. Compatible with any GPS/ GPRS tracker
7. Possibility of autonomic usage

includes:

1. Data processing box (1 pcs.)
2. Ultrasonic radiator with cable (2 m)
3. Interface cable (2 m)
4. Rainproof cover (3 pcs)
5. Acoustic glue
6. Cable yokes (4 pcs.)
7. Screws for processing box (1) fixation (4 pcs.)
8. User's manual

Accessories (not included) :

1. Extension cable 6meters
2. Programmer (reader)
3. Installation magnet
4. Extension cable for the ULM -programmer
5. Cable for 485 port

## Indication, connection and tuning tools

There are 3 LEDs on the top of the processing box (pic. 2).

1. **Red** – power supply indicator. The LED is on when the power supply is fed to the processing box 1
2. **Green** – indicator of the fuel level in the tank. The indicator has 2 modes:
  - a. Measuring mode. The indicator blinks when the fuel level in the tank is below 30 mm.
  - b. Tuning mode. (See chapter Installation, item Installation of the ultrasonic radiator). The indicator blinks with different frequency depending on the level of received signal.
3. **Yellow** – indicator of the battery level. The indicator blinks when the level on the built-in battery is below 1.5 V. In this case you should change the battery.

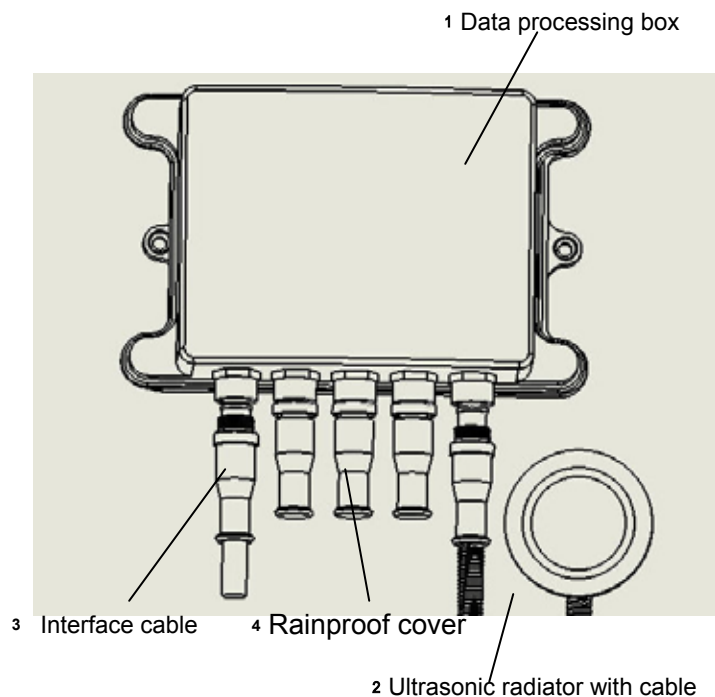

**Ultrasonic radiator socket** – for connection the ultrasonic radiator 2 to the processing box 1 .

**Port USB** – for connection to PC (for the service only).

**Port 1. EIA485 / UART** – for connection the processing box 1 to external equipment via digital interface EIA485. For example, GSM / GPS terminals.

Or for making settings and reading data from ULM 1.1 built-in memory via ULM -programmer (reader). UART interface is for service only.

**Port 2. EIA485/UART** – for connection the processing box 1 to ULM -programmer (reader) for service.

**Multi-interface socket** – for connection the processing box 1 to the vehicle power supply net and to external transmitters for online monitoring of the fuel level.

See the multi-interface socket contacts description in the pic.3.

1&5. Not use

See the analog signal description in the Table 1.

Table 1

Voltage on CD Out, V CD Out ( V )	Status
2.5	Normal functioning
1.9	No signal from the ultrasonic radiator
1.3	The ultrasonic radiator cable break
0.9	Low battery
0.1	Low battery + The ultrasonic radiator cable break or no signal from the ultrasonic radiator

2. **GND** – ground.

3. **IGN** – ignition wires.

4. **CD OUT** – analog signal output of the fuel-level meter status in «Self-t

6. **Analog OUT** – «Analog output». Voltage of the signal linearly depends on the fuel level in the tank. The voltage range is 0,3 – 9,6 V.

For better precision of the output data it is necessary to set the maximum of the fuel level. This setting is to be made by micro-switches. See the description in the pic. 4 and the Table 2. es of the fuel-level meter.

7. **Digital OUT** – «Frequency output». Frequency of pulses of this

signal depends on the fuel level in the tank. The frequency range

is 500 – 1500 Hz, amplitude of the signal is 10 V

8. **+12/24 ACC** – power.

**Settings of the micro-switches**

The processing box 1 has a group of micro-switches (pic. 4) to set different mod

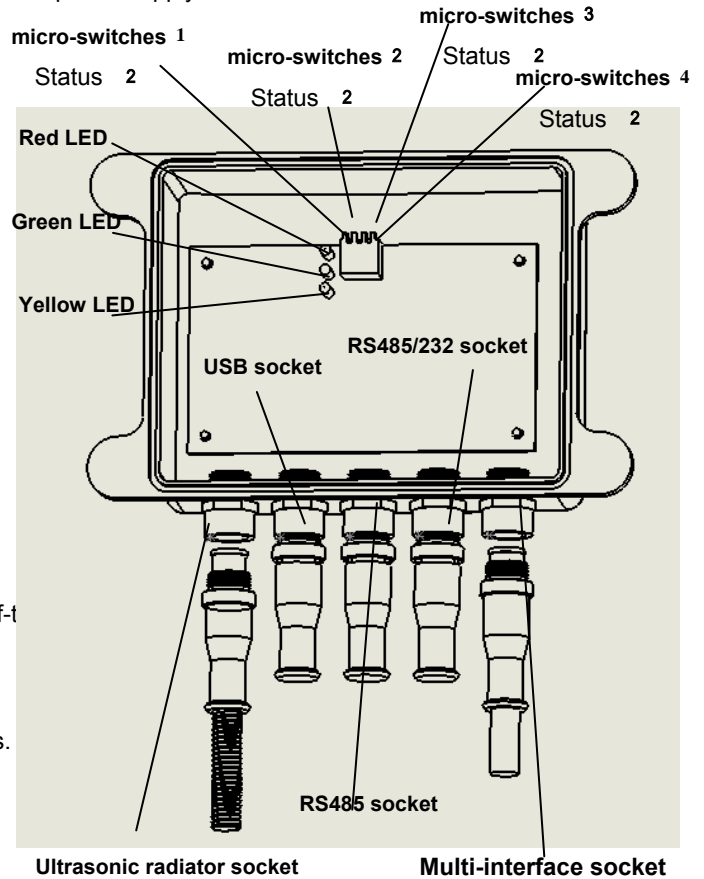

Pic. 4.

Table 2. Description of the micro-switches positions.

Switch N	Position	Setting	Picture
1	1	Test mode – ON.	
	2	Test mode – OFF (Measurement).	
2 3	1	Limit of effective range 30 cm.	
	1		
2 3	2	Limit of effective range 45 cm.	
	1		
2 3	1	Limit of effective range 60 cm.	
	2		
2 3	2	Limit of effective range 80 cm.	
	2		
4	1	Power supply from battery - ON.	
	2	Power supply from battery - OFF.	

## Installation

### Connection to the power vehicle supply net

1. Connect the ultrasonic radiator 2 to the processing box 1.

**Make sure that the Rainproof cover should be connected to the processing box 1 by the connector with box screw tight. (refer to the pic. 5).**

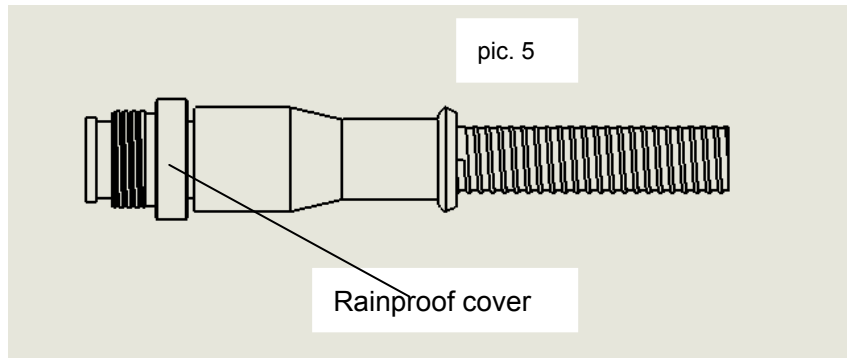
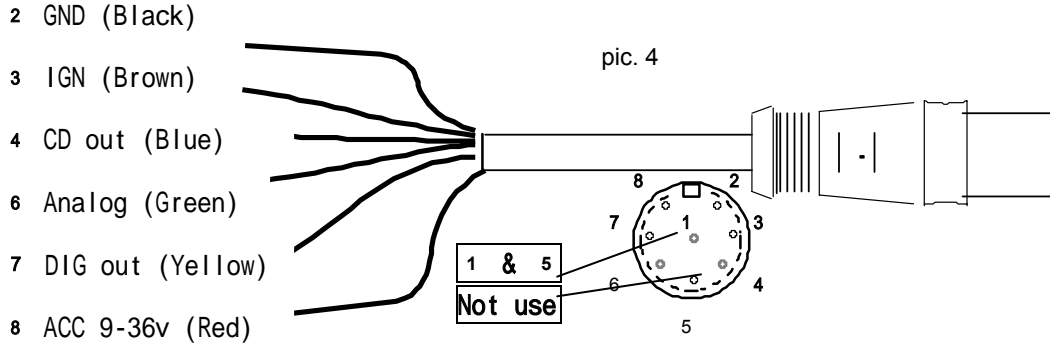

2. Put the Ultrasonic radiator with cable into a protective corrugated pipe and lay along the chassis frame or electric wiring run. The cable should be distanced formore than 20 cm from heated and moving elements of the vehicle. Fix the cable by the plastic yokes with an interval about 50 cm.
3. If necessary the extension cable of the radiator could be enlarged by an accessory – ULM extra extension cable of 6 meter length. But the total length should not exceed 16 meters.
4. Connect the processing box 1 to the power supply net by the cable 6. Pin out of the cable 6 is presented in the pic. 4.
5. Connect the red wire of the power supply + 12/24 ACC to the corresponding wire of the vehicle electric net through the 1 A fuse. Connect the black wire of the power supply «-» GND to the corresponding wire of the vehicle electric net through the 1 A fuse. Do not connect «Analog Out» wire to your transmitting equipment before the ultrasonic radiator is installed because this wire is used for procedure of searching of an optimal place for the ultrasonic radiator installatio.

### Installation of the ultrasonic radiator and the processing box

1. Fill the tank fully or at least for 2/3. This will help you to install the ultrasonic radiation with the best precision.
2. Place the vehicle on a horizontal surface, the tank should be in a horizontal position.  
If the tank was installed incorrectly and its position differs from the horizontal for more than 2 degrees correct the installation of the tank to make its position as close to horizontal as possible.
3. Set the limit of the effective range by the micro-switches 2 and 3 (refer to the pic. 4 and the Table 2).  
For example, if the height of the tank is 40cm choose the effective range 45 cm by putting the switch 2 in position 2 and switch 3 in position 1.
4. Choose 4 - 5 places for the ultrasonic radiator installation on the bottom of the tank. These places should be close to the center of the tank bottom and there should not be any partitions and other elements inside the tank over the chosen place.  
Make sure that the working surface of the radiator installed in the chosen palaces will be horizontal, as parallel to the fuel surface in the tank as possible and therefore the axis of the radiator should be close to vertical. (See pic. 7).
5. Clean the chosen place from the dirt and grains of sand.

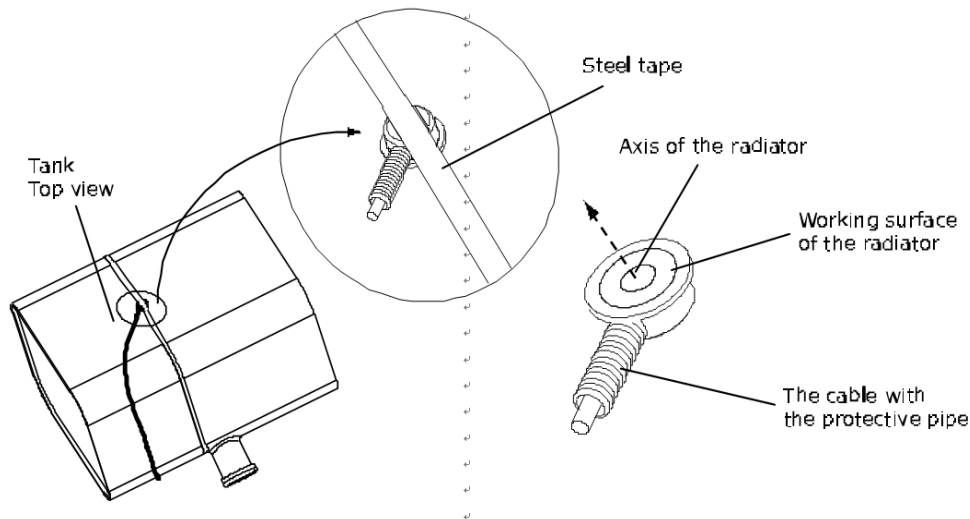

6. Connect a voltmeter to the wires «Analog Out» and «GND».
7. Coat the working surface of the radiator with some water. Water should be between the working surface of the radiator and the tank every time you press the radiator to the tank. **Make sure that there no grains of sand.**  
If the installation is performed under negative temperature use a lubricant instead of water. In this case after the place for the installation is chosen the lubricant should be completely removed and the place should be defatted.  
**Attention! Without an acoustic contact the ultrasonic radiator does not operate.**
8. Set the «Test» mode: put the micro switch 1 in position 1 (see the Table 2). Put the power off then on to start the «Test» mode. The green LED will start blinking.
9. Press the radiator to the chosen 4 - 5 places of the tank one by one and check the signals level:  
The green LED will blink with a frequency corresponding to the signal level. As higher the signal level as faster the green LED will blink. If the signal is maximum the blinking is almost invisible, the LED will shine constantly.  
**or / and**  
The voltmeter will register the voltage that varies in the range 0 - 9,6 V and directly proportional to the signal level.
10. Set the «Measurement» mode: put the micro switch 1 in position 2 (see the Table 2). Put the power off then on to start the «Measurement» mode.  
The green LED will be off.
11. Press the radiator to the chosen 4 - 5 places of the tank one by one again and check the signals level:  
The voltmeter will register the voltage that varies in the range 0 - 9,6 V and directly proportional to the fuel level.
12. The best place for the radiator installation is the place where the signal was higher in the «Test» mode and the voltage is not less than 7 V in the «Measurement» mode.

**Example:**

The 1st, 2nd and 3rd checked places give 6 - 9,6 V in the «Test» mode and 7 V (+/- 0,1 V) in the «Measurement» mode 5 V (+/- 0,1 V).  
The 4th and 5th places have in the «Test» mode 9,6 V and in the «Measurement» 0,15 - 1,5 V.

The 4th and 5th places give 9,6 V in the «Test» mode and 0,15 - 1,5 V in the «Measurement» mode.

This means that the 4th and 5th places have a bad signal. So you have to choose one of the first 3 places which has the highest voltage in the «Test» mode.

13. Remove the paint from the chosen place completely till the metal and put a layer of an acoustic glue (not included into the set). The glue should be prepared according to its instruction. Air bubbles in the glue are not acceptable.
14. Press the working surface of the radiator to the glue.  
The glue will stiffen in 24 hours. Therefore it is recommended to fix the radiator with a steel tape of 16 mm width (not included in the set) laid in the gap of the radiator. For tighten the steel tape you can use the machine packing tool M4K (not included in the set). As well you can use the installation magnet (not included in the set) which should be taken away after the glue stiffened.  
**Remark: Stiffening of the glue could be shortened till 1 hour by heating to 60° C using a heat gun.**
15. When the glue is stiffened completely check the voltage in the «Test» mode again. It should be stable 7 - 9,6 V and the green LED should shine constantly.
16. Put the fuel-level meter in the «Measurement» mode (put the micro-switch 1 in position 2 and restart power)
17. If the fuel-level meter will be used in the autonomic mode (UZI-M-1.1. modification) without connection to a terminal GSM / GPRS transmitter set the micro-switch 4 in position 1 (see Table 2). Thereby the built-in battery will be switched on. It provides nonvolatile timer for data and time.  
**Remark: Current date and time should be set by a dialer or a service center.**  
If the fuel-level meter will be connected to a GPS / GPRS transmitter (UZI-M-1.2. modification) set the micro-switch 4 in position 2 (see Table 2).
18. Put the seal label over the micro-switched.
19. Fix the processing box 1 by the 3M double side scotch **or / and** 4 screws in the driver's cabin and connect the wires of the cable 6

according to the  
pic. 6.

**Remark: If the fuel-level meter will be used in autonomic mode (without connection to a terminal GSM / GPRS transmitter) the processing box should be good accessible for connecting the special uploading cable.**

20. Connect the wires «+12/24 ACC» and «GND» to the vehicle power supply net. If the vehicle has a switch of GND the connection should be made after the switch).

Terminal navigation equipment should be connected after the GND switch as well. If it is necessary to connect the devices before the GND switch the circuitry of the both devices should have a galvanic isolation (not included in the set).

**ATTENTION! DISCONNECT THE MULTI-INTERFAE CABLE FROM THE PORT 1 AND THE ULTRASONIC RADIATOR FROM THE PROCESSING BOX IN CASE OF ANY ELECTRICAL OR WELDING REPAIRS OF THE VEHICLE.**

### Operating in a system with GPS / GPRS transmitters

Ultrasonic fuel-level meter can operate in a system of collecting and transmitting data such as GPS / GPRS transmitters. For the connection to the transmitter the fuel-level meter has several analog and digital interfaces.

If the GPS / GPRS terminal has analog-to-digital convertor the following outputs could be used:

1. «Digital Out» – «Frequency output signal». Frequency of pulses of this signal depends on the fuel level in the tank. The frequency range is 500 - 1500 Hz, the amplitude of the signal is 10 V.
2. «Analog Out» – «Analog output signal». Voltage of the signal linearly depends on the fuel level in the tank. The voltage range is 0,3 – 9,6 V.

For better precision of the data displayed by the both outputs it is necessary to set the maximum of the fuel level. This setting is made by micro-switches. See the description in the pic. 4 and the Table 2.

Additionally the analog output «CD Out» could be connected to the corresponding input of the transmitter. In this case error diagnostic information (see the Table 1) will be sent to the transmitter.

If the GPS / GPRS terminal has digital inputs the fuel-level meter could be connected via digital interfaces (see pic. 2). In this case the data will be transmitted via EIA485 interface according to a specialized protocol.

The specification of this protocol could be supplied by a special request.

Connection of the fuel-level meter to the GPS / GPRS terminal should be made via a special cable (not included in the set). See the pin-out description of the special cable in the pic. 8.

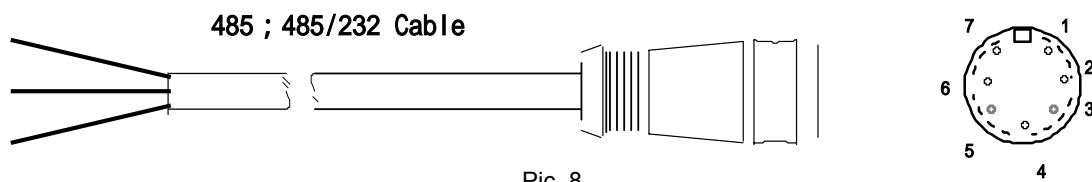

Pic. 8

To recalculate the fuel level (mm) to volume (liter) it is necessary to use a calibration sheet of the fuel tank. The calibration sheet could be separately (visit [www. JUNTRY.com](http://www.JUNTRY.com)).

### Operating in autonomic mode

Ultrasonic fuel-level meter can operate in autonomic mode. In this mode the fuel-level meter works as a «black box» saving up data of the fuel level changes throughout 30 days.

The following data is saved in the nonvolatile memory:

1. Current date;
2. Current time;
3. Fuel level (mm) or volume (liter) (see more information on [www. JUNTRY.com](http://www.JUNTRY.com));
4. Temperature mode of the ultrasonic radiator;
5. Status of the fuel-level meter;
6. Ignition (if IGN wire connected);
7. ID of the fuel-level meter

The fuel-level meter has a built-in battery for saving the current date and time. Before the installation and usage check the micro-switch 4 which should be set in position 1 (see the Table 2).

**ATTENTION! If the power is cut-off (disconnected from the vehicle power supply net) and the micro-switch 4 is in position 2 the current date**

**and time will be lost. Correct date and time could be set only via a special equipment and software supplied separately.**

After 30 days new data will be re-written over the earliest data.

Saved data could be uploaded via UZI-programmer (reader) and special software supplied separately.

If the yellow LED start blinking the built-in battery is discharged and it should be substituted.



**The product is certified.  
After sale 12 months guarantee.**

Make the guarantee request immediately after a faultiness or defect is found.  
The guarantee does not cover restitution of direct or indirect losses or damages.  
The guarantee for the components (battery and cables) is 6 months.

The conditions of this guarantee and the extent of responsibility of the manufacturer under this limited guarantee are as follows:

- This guarantee is limited to the original purchaser of the product and is not transferable to any subsequent purchaser / end user.
- During the guarantee period, the sole responsibility of the manufacturer will be limited to repair or replace, at its option, any defective parts of the product if this is needed because of malfunction or failure under normal use and conditions.  
No charge shall be made to the customer for parts and / or repair labor.
- The product must be shipped to the manufacturer in its original and complete packaging, with transportation charges prepaid. The manufacturer will not assume responsibility for any losses or damages during transportation.
- To obtain repair or replacement within the terms of this guarantee, the customer must provide:
  - (a) a proof of purchase (e.g. dated bill of sale);
  - (b) a written specification of the defect(s);
  - (c) a return address and phone number.
- This guarantee does not cover and is void with respect to the following:
  - (a) Products which have been subjected to improper installation, unauthorized repair, improper maintenance, unauthorized modifications or other acts which are not the fault of the manufacturer;
  - (b) Products which have been subjected to misuse, abuse, neglect, improper handling and storage, an accident or physical damage;
  - (c) Products which have been subjected to fire, water, excessive humidity, sand, dirt, extreme changes in temperature or other conditions which are beyond the control of the manufacturer;
  - (d) Products which have been used with non-manufacturer approved accessories;
  - (e) Products which have the serial number altered, defaced or removed;
  - (f) Products which have been opened, altered, repaired or modified by any unauthorized service center.
- Excluded from any guarantee are consumable items which may need replacing due to normal wear and tear, such as batteries, cables, decorative parts and other accessories.
- This guarantee gives you specific legal rights, and you may also have other rights which vary from country to country.

**Model**

**Serial number**

Seller	Buyer
Signature _____ /	/ Signature _____ /
Date	Date
Stamp	Stamp